

## Copper distribution associated with various water masses in the Yellow Sea

Kazuo ABE\*

---

**Abstract** The distribution of dissolved copper (Cu) was investigated in January (winter) and September (autumn) of 1995 in the central Yellow Sea and found to be influenced by the variation in the components of the water mass. Cu was plotted against the salinity, and the points plotted were classified into three groups corresponding to the characteristics of three types of water masses: the water influenced by the enhanced discharge of the Huanghe and the Changjiang, the Yellow Sea Cold Bottom Water (YSCBW), and the bottom water with high salinity and high temperature originated from the Kuroshio.

**Key words:** Cu distribution, Cu - salinity plot, the Huanghe and the Changjiang, the Yellow Sea

---

### Introduction

Copper (Cu) is a trace metal that is harmful to marine organisms (e.g., Flemming and Trevors, 1989), and its existence in seawater influences the primary production (Sunda and Guillard, 1976). Generally, the reported concentration levels ranged between 0.5 to 8 nM in the open ocean, and the vertical distribution showed Cu to be of the nutrient type (e.g., Bruland, 1980). On the other hand, in the coastal and estuary areas, Cu sometimes behaved conservatively, showing a good correlation with the salinity (e.g., in the Amazon and the Changjiang estuary) (Boyle *et al.*, 1982; Edmond *et al.*, 1985), and the regional characteristics of the Cu distribution have not been thoroughly explored.

This study shows the distribution of Cu in connection with that of the water mass in the Yellow Sea. The data set was collected from a limited number of points in the Yellow Sea, and the sampling was conducted approximately 10 years ago. Therefore, although the information

is too limited for a thorough discussion of the current conditions of the Yellow Sea, the objective of this paper is to describe the distribution of Cu in order to use the information as a reference for evaluating the environmental changes in the study area.

The Yellow Sea is a typical marginal sea adjacent to the East China Sea, and the oceanographic conditions are significantly influenced by the variation in the discharge from large rivers, such as the Huanghe and the Changjiang, which discharge 42km<sup>3</sup>/year and 950km<sup>3</sup>/year of water, respectively (Yanagi, 1994). The discharge of these rivers fluctuates seasonally (Hayami, 1938; Beardsley *et al.*, 1985; Edmond *et al.*, 1985; Zhang, 1995): the peak discharges of the Huanghe (about 2,200m<sup>3</sup>/s) and the Changjiang (more than 50,000m<sup>3</sup>/s) usually occur in summer, and low discharges, which are about 1,100m<sup>3</sup>/s for the Huanghe and about 10,000m<sup>3</sup>/s for the Changjiang, occur from winter until spring (Beardsley *et al.*, 1985; Chen *et al.*, 1994). Considering these riverine characteristics (discharge), Zhang (1995) described the

---

2003年4月9日受理 (Received on April 9, 2003)

水産総合研究センター業績 A 第38号 (Contribution No. A 38 from the Fisheries Research Agency)

\* 西海区水産研究所石垣支所 〒907-0451 沖縄県石垣市椶海大田148-446 (Ishigaki Tropical Station, Seikai National Fisheries Research Institute, 148-446 Fukai-Ota, Ishigaki, Okinawa 907-0451, Japan)

conservative behavior of dissolved Cu in the Huanghe estuary, where the salinity was more than 30, and in the Changjiang estuary, where the salinity was from 0 to approximately 32. The detailed regional circulation pattern in the Yellow Sea is described elsewhere (Beardsley *et al.*, 1985; Chen *et al.*, 1992; 1994).

### Sampling and methods

Water samplings were carried out vertically in the central Yellow Sea aboard the R/V Yoko-Maru of the Seikai National Fisheries Research Institute (SNFRI) in January (winter) and September (autumn) of 1995 (YK 94-07, 95-06 cruise) (SNFRI, 1996; 1997) (Sts. 1, 2, and 3 in Fig. 1), with an acid-cleaned Go-flo water sampling bottle hung on a nylon rope attached to a steel wire to avoid contamination from the wire. Station 2 was the only station where seawater samples were collected in the autumn and winter surveys. In this study, the periods from December to February and from September to November were defined as winter and autumn, respectively. The water samples for dissolved Cu determination were transferred to acid-cleaned 1000-mL polyethylene bottles covered with double plastic bags and frozen ( $-40^{\circ}\text{C}$ ) immediately after sampling until analysis

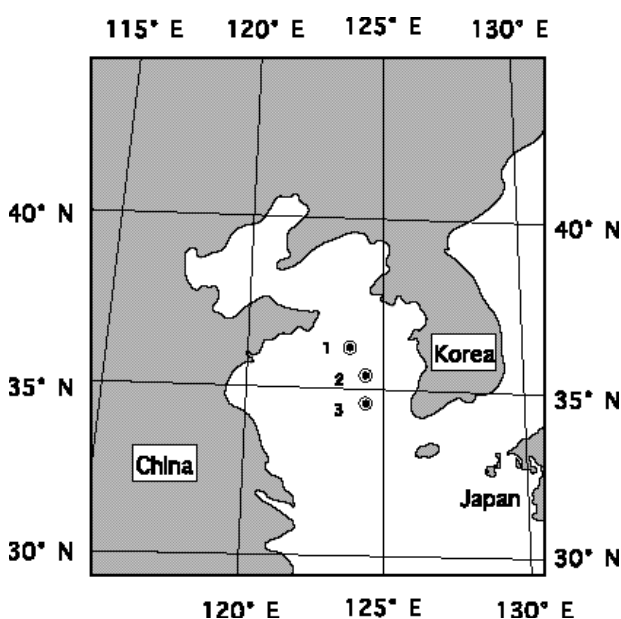

Fig. 1. Sampling sites in this study

in a land-based laboratory. Cu in samples filtered through a  $0.6\text{-}\mu\text{m}$  Nuclepore filter was concentrated by the modified APDC coprecipitation method of Boyle and Edmond (1977) before determination using Inductively Coupled Plasma Atomic Emission Spectrometry (ICP-AES). In this paper, Cu passed through a  $0.6\text{-}\mu\text{m}$  Nuclepore filter is defined as "dissolved." Briefly, the analytical procedure of Cu is as follows: A cobalt chloride solution was added to 1000 mL of filtrate (seawater sample) through a  $0.6\text{-}\mu\text{m}$  Nuclepore filter and swirled gently to mix. An APDC solution was added and swirled thoroughly to prepare a Cu-APDC precipitate. After standing for 5 minutes, the Cu with the precipitate was recovered by filtering through the  $0.6\text{-}\mu\text{m}$  Nuclepore filter. The filter was put into a Teflon bomb with 250  $\mu\text{L}$  of concentrated  $\text{HNO}_3$  and left at  $70^{\circ}\text{C}$  for 1 hour. After cooling, the solution was diluted by Milli-Q water, and Cu was determined by using ICP-AES (Nippon-Jarrell-Ash ICAP-575 MARK ). A standard addition method was adopted for Cu determination to correct the matrix interference. The standard solution used was prepared from commercially available material (1,000ppm, Wako Chemicals). All the procedures for Cu analysis were conducted in a laminar flow bench. The analytical error in a single determination of dissolved Cu was estimated to be 6.7% (95% confidence level) at the concentration of 2 nM, and the analytical detection limit of the methodology used in this study, defined as twice the standard deviation of the blank signal, was 0.20 nM. The typical reagent blank for Cu was 0.21 nM. Salinity and temperature were measured using a CTD in OCTOPUS, an Octo Parameter Underwater Sensor (Ishimaru *et al.*, 1984).

### Results and discussion

#### Distributions of the temperature, salinity, and dissolved Cu

Data from the seawater analysis are listed in Table 1. In winter (January), the water column at St. 2 was well mixed, and almost homogene-

ous vertical distributions for temperature, salinity, and Cu were observed (Table 1). Figs. 2 and 3 show the distributions of temperature and salinity, respectively, in autumn (September). At a depth of around 25 m, a seasonal thermocline clearly developed, and there was relatively less recognizable saline water (less than 32.6) in the surface layer. This water mass seemed to be influenced by the enhanced discharge of the Huanghe and the Changjiang in this season. The existence of low salinity water in the surface layer (above the thermocline) generally agreed with previous reports, showing the dilution with riverine water. The big rivers such as the Huanghe and the Changjiang enhanced its discharge in this season due to increased rainfall and spring melting of the winter snow pack (Beardsley *et al.*, 1985; Chen *et al.*, 1994). Below approximately 40m, water colder than 10°C with a high saline content was found at Sts. 1 and 2. This water mass was the Yellow Sea Cold Bottom Water (YSCBW), which was formed by vertical mixing during winter cooling and remained in the bottom layer from

summer to autumn (Inoue, 1975; Matsumiya *et al.*, 1977). Kondo (1985) described the water mass (YSCBW) as being cold, less than 10°C, with a salinity of around 33 in the middle and bottom layers of the central Yellow Sea from spring to autumn. This water mass was the remainder of the cold water produced during the winter as the Yellow Sea Warm Current Water, the Chinese Coastal Water, and the Korean Coastal Water mixed. It was assumed to be stagnant water with little change in its physicochemical characteristics. In this research, the water mass of the YSCBW was defined to be 9-10°C with 32.6-32.9 of salinity. The existence of highly saline water (over 32.9 of salinity) was observed near the bottom and below the thermocline at Sts. 1 and 3, respectively. It was assumed to be the water influenced by a northward penetration of bottom water that originated from the Kuroshio and mixed with the water on the continental shelf. In summer (from July to September in Kondo (1985)), the salinity in the bottom layer of the central and northern East China Sea and central Yellow

**Table 1.** Seawater analysis results

Depth (m)	Temperature( °C)	Salinity	Cu (nM)
St. 2 (winter: 1995.1.20)			
5	8.957	32.668	5.21
35	8.927	32.672	5.28
67	8.708	32.769	5.15
80	8.811	32.836	4.74
St. 1 (autumn: 1995.9.7)			
5	25.442	31.426	7.89
21	14.418	32.446	4.57
37	9.629	32.598	5.60
53	8.936	32.817	5.83
70	9.272	32.968	6.32
St. 2 (autumn: 1995.9.7)			
5	25.811	31.538	8.33
22	15.979	32.371	4.59
40	9.003	32.783	5.76
60	8.683	32.760	5.47
80	8.592	32.753	5.83
St. 3 (autumn: 1995.9.8)			
5	26.035	31.615	7.06
22	23.263	32.132	3.95
40	10.281	33.207	4.76
60	10.059	33.240	5.24
70	10.066	33.268	5.50

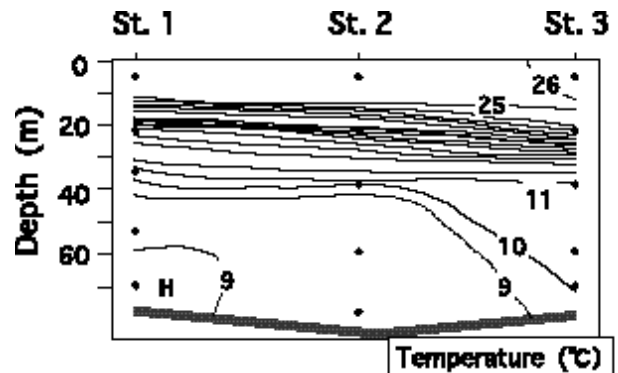

**Fig. 2.** Distributions of temperature

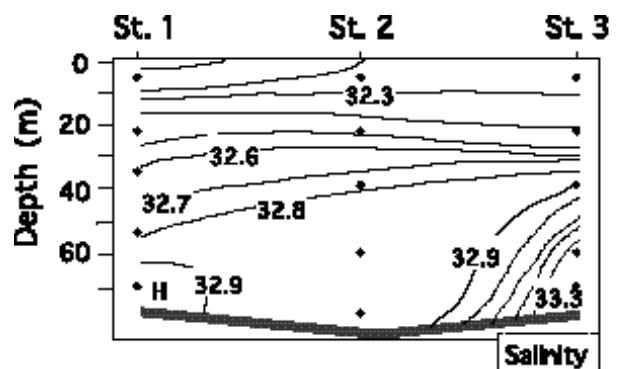

**Fig. 3.** Distributions of salinity

Sea increased because of the northward movement of the water that had originated in the Kuroshio, and its influence extended to the mouth of the Changjiang, showing a salinity of around 34, which indicated that it was Kuroshio water (Kondo, 1985). The northward penetration of this water mass in the bottom layer is assumed to compensate for the enhanced outflow from the Yellow Sea by the surface southward current along the Chinese coast in summer (Kondo, 1985). Although a clear definition of the water mass classification using the temperature and salinity data is not fixed, judging from the distributions of salinity and temperature in this study, the three water masses in this study consisted of the water influenced by enhanced river discharge (above the thermocline in autumn and with a salinity of less than 32.6), the YSCBW (32.6-32.9), and the bottom water influenced by the penetration of the Kuroshio originated water (more than 32.9), as shown in the T-S diagram in Fig. 4.

The vertical profiles of Cu and the transect distribution of Cu in autumn are illustrated in Figs. 5 and 6, respectively. The dissolved Cu concentrations were in the range of approximately 4 to 8 nM, similar to those obtained

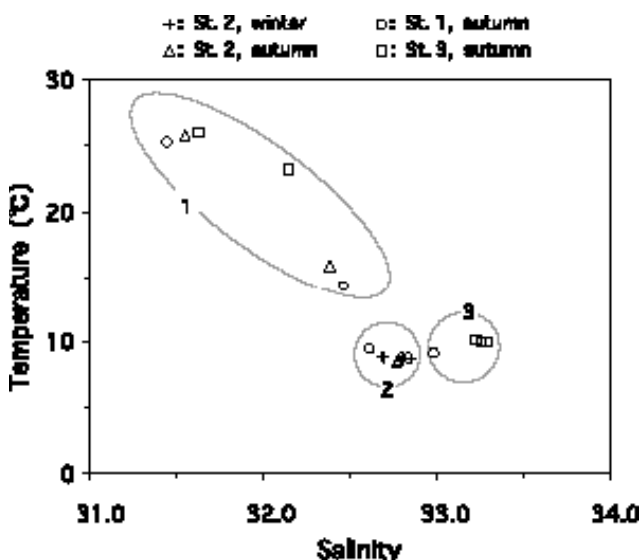

Fig. 4. T-S diagram. Three water masses were classified as "1", "2", and "3" corresponding to the water mass influenced by the discharge of the Huanghe and the Changjiang, the Yellow Sea cold bottom water (YSCBW), and the bottom water originated from the Kuroshio, respectively.

from the continental shelf of the eastern Bering Sea (Heggie *et al.*, 1987). An almost homogeneous vertical profile observed in winter is attributed to winter convection with a concentration of around 5 nM. In autumn, surface concentrations (at strictly 5 m in depth, where the average concentration of Cu was 7.8 nM) were higher than those in the deep water, and the minimum at around 25 m was observed at each station. The water depth (around 25 m) where the minimum concentration layer (shown as "L" in Fig. 6) was observed corresponded to the center of the thermocline. Below the minimum, concentrations tended to increase gradually toward the sea bottom. At St. 1, a high concentration of over 6 nM was observed near the bottom, corresponding to the features (high salinity and high temperature) of water at the same depth. At St. 3, Cu in the bottom layer tended to be lower where the saline and high-temperature water mass penetrated.

#### Cu-salinity plot

These Cu data were plotted against the salinity (Fig. 7). In winter, points plotted clustered around the Cu concentration of 5 nM due to the effect of vertical water mixing during the winter convection period, and this cluster was considered to indicate the Cu-salinity characteristics of the YSCBW. In autumn, the plotted

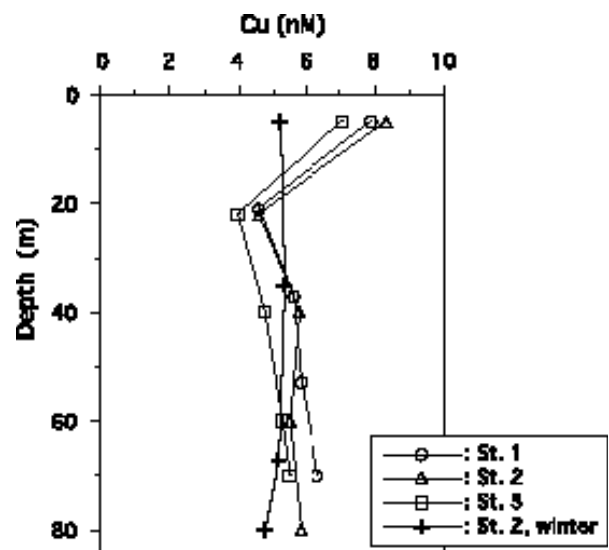

Fig. 5. Vertical profiles of Cu

data were classified according to the salinity data into three groups, i.e., less than 32.6, 32.6-32.9, and over 32.9, corresponding to the surface layer above the thermocline, the YSCBW, and the bottom water originated from the Kuroshio, respectively, as noted in the previous chapter. In autumn, in the first category (above the thermocline), there was less saline water that was influenced by the enhanced discharge of the Huanghe and the Changjiang. The plotted points shown by closed circles and triangles in Fig. 7 fluctuated toward the upper left area between the Huanghe and the Changjiang dilution lines shown in Zhang (1995); however, the data for these lines were obtained more than 10 years ago. Therefore, it is possible that the distributional pattern of Cu could have changed

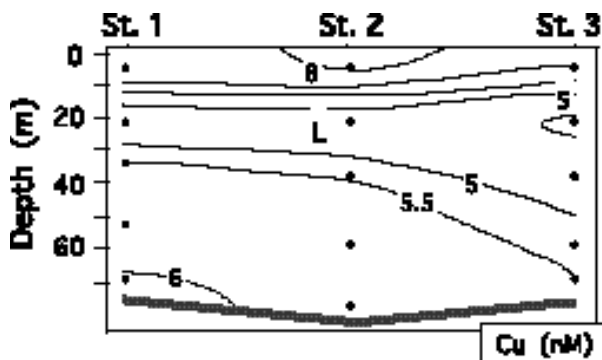

Fig. 6. Distributions of Cu

considerably since then. Abe *et al.* (2003) estimated the influence of the Changjiang water on the elevated Cu concentrations in the surface water in autumn, which is shown in the Cu-salinity plots from the data above the thermocline in this study. The YSCBW (a salinity of 32.6-32.9) belonged to the second category, and it was also identified with the Cu-salinity plot. As noted in the previous chapter, this water mass was formed in winter by the vertical mixing from the surface to the sea floor, and part of this water remained below the thermocline until autumn. Plotted points were clustered in a narrow range in autumn, and winter data in 1995 were close to this cluster, although there seemed to be a little variance in the plot between the two seasons. In the third group, in which the salinity was more than 32.9, four points from St. 1 (bottom) and St. 3 (below the thermocline) were plotted, and, in the Cu-salinity plot, the points in this group were located above the dilution line for the Huanghe estuary. Kremling (1985) and Nolting (1986) suggested that the elevated Cu concentrations in the northwest European shelf could be attributed to the diagenetic remobilization of Cu from partly reduced sediments to the overlying bottom water. In this study area, the Cu

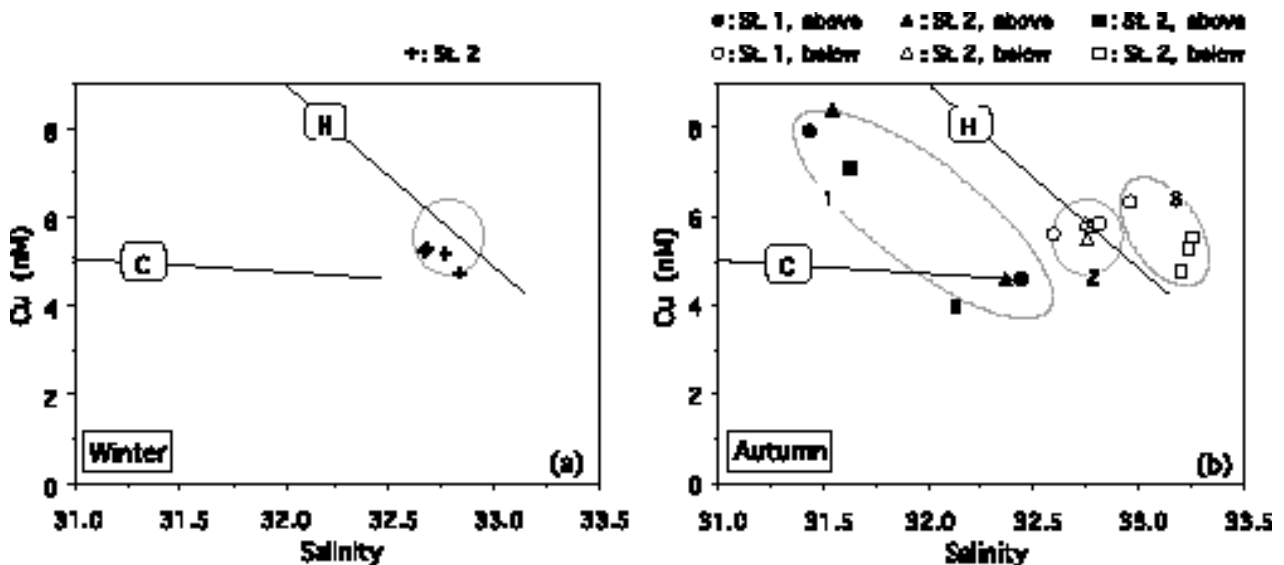

Fig. 7. Cu-salinity plot. Cu concentrations are plotted against the salinity data, and lines with the letters "H" and "C" denote the dilution line of the Huanghe and the Changjiang estuaries, respectively, as shown in Zhang (1995). The circle surrounding the data in Fig. 6a (in winter) corresponds to the number 2 circle in Fig. 6b (in autumn). Three groups were classified as "1", "2", and "3" in Fig. 6b corresponding to the water masses shown in Fig. 4.

release from the sediments by the remobilization to the overlying water (the bottom water originated from the Kuroshio) may also be significant because this water mass was assumed to pass above the continental shelf from the East China Sea.

### Conclusion

Cu distributions in the Yellow Sea were discussed in the connection with the water mass component. In the limited study area, the Cu-salinity plot corresponded to three water masses, such as the water influenced by the river discharge, the YSCBW, and the bottom water originated from the Kuroshio. The Cu-salinity plot is a possible tool for the water mass analysis in the Yellow Sea.

### Acknowledgments

I gratefully acknowledge the officers and crew of the R/V Yoko-Maru of the Seikai National Fisheries Research Institute for their help with the sampling.

### References

- Abe K., Ishihi Y., and Watanabe Y., 2003: Dissolved copper in the Yellow Sea and the East China Sea-Cu as a tracer of the Changjiang discharge-. *Deep-Sea Res.* , **50(2)**, 327-337.
- Beardsley R. C., Limeburner R., Yu H., and Cannon G. A., 1985: Discharge of the Changjiang (Yangtze River) into the East China Sea. *Continent. Shelf Res.*, **4**, 57-76.
- Boyle E. A. and Edmond J. M., 1977: Determination of copper, nickel, and cadmium in sea water by APDC chelate coprecipitation and flameless atomic absorption spectrometry. *Analy. Chim. Acta*, **91**, 189-197.
- Boyle E. A., Husted S. S., and Grant B., 1982: The chemical mass balance of the Amazon Plume-II. Copper, nickel, and cadmium. *Deep-Sea Res.*, **29**, 1355-1364.
- Bruland K. W., 1980: Oceanographic distribution of cadmium, zinc, nickel, and copper in the North Pacific. *Earth Planet. Sci. Lett.*, **47**, 176-198.
- Chen C. S., Beardsley R. C., and Limeburner R., 1992: The structure of the Kuroshio southwest of Kyushu: Velocity, transports, and potential vorticity fields. *Deep-Sea Res.*, **39**, 245-268.
- Chen C., Beardsley R. C., Limeburner R., and Kim K., 1994: Comparison of winter and summer hydrographic observations in the Yellow and East China Seas and adjacent Kuroshio during 1986. *Continent. Shelf Res.*, **14**, 909-929.
- Edmond J. M., Spivack A., Grant B. C., Hu M.-H., Chen Z., Chen S., and Zeng X., 1985: Chemical dynamics of the Changjiang estuary. *Continent. Shelf Res.*, **4**, 17-36.
- Flemming C. A. and Trevors J. T., 1989: Copper toxicity and chemistry in the environment: A review. *Water, Air, and Soil Pollut.*, **44**, 143-158.
- Hayami S., 1938: Hydrological studies on the Yangtze River, China. *J. Shanghai Sci. Inst., Section I*, **7**, 97-162.
- Heggie D., Klinkhammer G., and Cullen D., 1987: Manganese and copper fluxes from continental margin sediments. *Geochim. Cosmochim. Acta*, **51**, 1059-1070.
- Inoue N., 1975: Bottom current on the continental shelf of the East China Sea. *Mar. Sci.*, **7**, 12-18 (in Japanese with an English abstract).
- Ishimaru T., Otobe H., Saino T., Hasumoto H., and Nakai T., 1984: OCTOPUS, an octo parameter underwater sensor for use in biological oceanography studies. *J. Oceanogr. Soc. Japan*, **40**, 207-212.
- Kondo M., 1985: Oceanographic investigations of fishing grounds in the East China Sea and the Yellow Sea-I. Characteristics of the mean temperature and salinity distributions measured at 50m and near the bottom. *Bull. Seikai Reg. Fish. Res. Lab.*, **62**, 19-66 (in Japanese with an English abstract).
- Kremling K., 1985: The distribution of

- cadmium, copper, nickel, manganese, and aluminium in surface waters of the open Atlantic and European shelf area. *Deep-Sea Res.*, **32**, 531-555.
- Matsumiya Y., Wada T., and Oka M., 1977: By the bivariate distribution of water type, the water mass analysis and the distribution of fishing ground of demersal fish in the East China Sea and the Yellow Sea. *Bull. Fac. Fish. Nagasaki Univ.*, **43**, 1-21 (in Japanese with an English abstract).
- Nolting R. F., 1986: Copper, zinc, cadmium, nickel, iron, and manganese in the southern bight of the North Sea. *Mar. Pollut. Bull.*, **17**, 113-117.
- SNFRI, 1996: Yoko-Marun Research Report, **19**, 119-125.
- SNFRI, 1997: Yoko-Marun Research Report, **20**, 62-67.
- Sunda W. and Guillard R. L., 1976: The relationship between cupric ion activity and the toxicity of copper to phytoplankton. *J. Mar. Res.*, **34**, 511-529.
- Yanagi T., 1994: Material transport in the Yellow/East China Seas. *Bull. Coast. Oceanogr.*, **31**, 239-256 (in Japanese).
- Zhang J., 1995: Geochemistry of trace metals from Chinese river/estuary systems: An overview. *Estuar. Coast. Shelf Sci.*, **41**, 631-659.