

Improved model of micro bathythermograph system for tuna longline boats and its application to fisheries oceanography

Makoto OKAZAKI*, Keisuke MIZUNO*, Tomowo WATANABE* and Shin'ichiro YANAGI**

Abstracts

Improved micro bathythermograph system for tuna longline boats has been developed based upon the results of in-situ experiments of prototype model. The system is changed to a multi-probe system such as simultaneous observation by several probes, and is linked to GPS so as to obtain real-time location data automatically. The multi-probe system has been bound to be very useful for fisheries studies. With the obtained data from several probes attached to longline, it enables to detect underwater shape of longline, and is probable to obtain the hooking data of tunas to a practical level. By linking to GPS, the system gives to the gear a function of drifter which is useful for oceanographic studies. Software for data processing on deck is also developed. Other feasibility of this system is also discussed.

Introduction

Previously, we designed and manufactured a micro-BT (BathyThermograph) system suitable to tuna longliners which are widely operating in the tropical and subtropical waters (Mizuno et al., 1996). Main purpose of the previous system was to obtain upper ocean thermal data efficiently for mapping of basin scale thermal field taking advantage of global scale operating area of longliners. The prototype system was tested repeatedly by attaching the probes to longline during a cruise and it achieved a adequate level of performance (Mizuno et al., 1996). Its applicability to fisheries or related biological studies was also suggested. A micro-BT attached to the gear was able to monitor the depth of a hook, which is considered an important information for longline operation. Moreover, it supplied biological information such as swimming depth/temperature, hooking time and behavior of hooked fish.

However, several problems were identified with the prototype system. One of the major problems was that the prototype model has been designed for single probe use. Although a single probe was enough to obtain vertical temperature profile, multi-probe system was strongly

1997年3月1日受理 遠洋水産研究所業績 第341号

*遠洋水産研究所 (National Research Institute of Far Seas Fisheries)

5-7-1 Orido, Shimizu-Shi, Shizuoka, 424 JAPAN

**(株)村山電機製作所 (Murayama Electronics Co., Ltd.)

2-13-1 Gohongi, Meguro-ku, Tokyo, 153 JAPAN

desired for fishing operation. In order to obtain set depths of hooks for a basket or to estimate underwater shape of main line, many probes must be used simultaneously. Multi-probe system is also essential for acquiring relevant information for biological studies, since the probability of obtaining a hooking data by a single probe is low.

Another problem was that the prototype model lacked a function of automatic acquisition of observing position. The lack of this function is not only to make the observation task more troublesome, but also miss the drifting velocity of longline.

Minor issues caused by the hardware in a probe (i.e., small noise of depth/temperature data, unchangeable data sampling interval etc.) had to be solved. Functions of on-deck software for the prototype system had been kept minimum. So, it was necessary to improve a software which could control entire system and manipulate obtained data in a convenient way.

In order to overcome above problems, we designed and manufactured an improved system. In this paper, outline of the improved model is described and its applicability tested in several in-situ experiments is shown and discussed.

Features of the improved model

(1) Overview

Designing concept of the improved system was consistent with the previous prototype system. The basic idea of improvement was to modify the system to make it more suitable from oceanographic/fisheries points of view.

A sketch of the improved model is shown in Figure 1. The system consists of four units, i.e., probes, array of pods, controller (computer) and GPS receiver. The array has twelve pod units (4×3), and each unit is separable. One can choose the number of the pods arbitrarily from 1 to 12. The power supply and interface unit are installed in a trunk together with pod array. GPS receiver is connected to the controller.

The way of operation is the same as the previous model. The probes are put into the pods for charging power before observation. Once taken out of the array of pods, the probes begin to record depth/temperature (D/T) data at a certain sampling interval. The probes are launched in the sea with fishing gear and retrieved on deck, then the probes are put into the pods again. The stored data in the probes are transferred to the computer memory via pods, and the pods simultaneously recharge the probes.

(2) Design of multi-probe system

The prototype model had only a single pod. Actual hooking rate of tunas/billfishes could be calculated to be 1-2% in the eastern tropical Pacific referring to a recent study of catch and hook number (Nakano and Bayliff 1992). According to another study (Resource department of Fisheries Agency of Japan 1982), similar hooking rate was shown in North/South/Eastern Pacific in 1980. Taking the hooking rate into account, 100 probes are needed in order to acquire one or

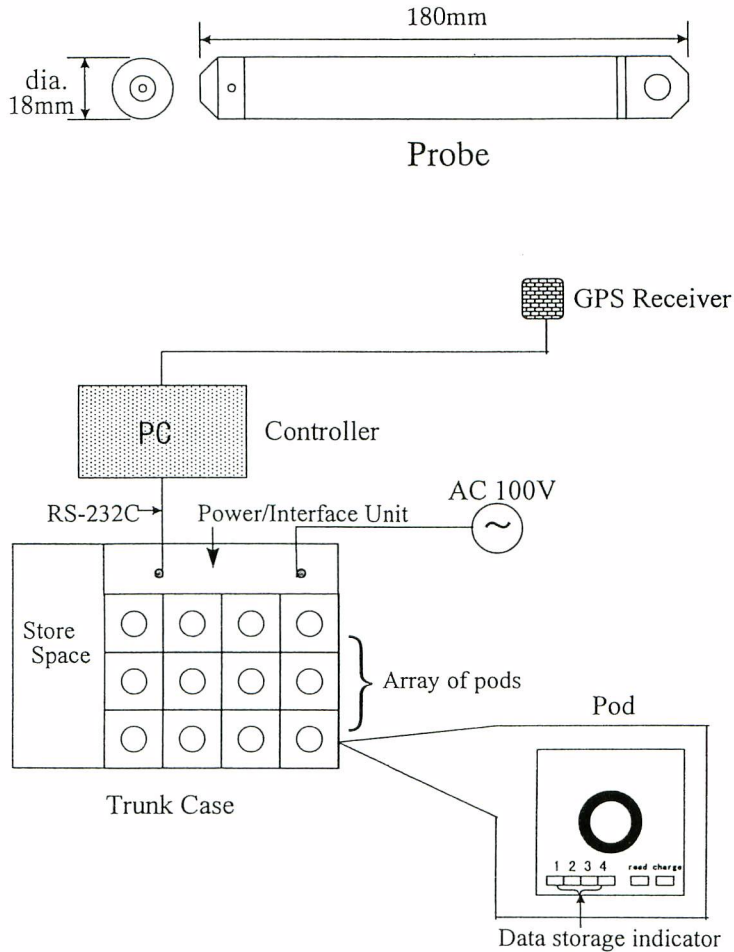

Fig. 1. A sketch of improved micro-BT system, probe (upper panel) and overview of the system with the enlargement of pod unit (lower panel).

two hooking data in an operation. However, operating 100 probes with 100 pods at a time is unrealistic in view of the cost and size of the system, power supply, computer memory and long processing time. Therefore optimum probe/pod number had to be decided.

The most serious restrictive factor is power supply to the array of pods which is consumed by charging probes. The maximum number of pods to be safely available is restricted to twelve due to power supply limit, although the number of probes is not appropriate to obtain hooking data. In order to alleviate this condition, a pod was changed so as to store obtained data of four probes temporarily. A pod has indicators (Figure 1) which display the number of data memorized in probes. Therefore, an array of twelve pods is able to store the data up to 48 probes ($12\text{pod} \times 4\text{data}$). A set of 48 probes is expected to obtain at least one hooking data in every two operations

by the application of the above mentioned hooking rate. It is considered to be an acceptable level.

The probe can be put into any pod, since each probe has individual ID number, therefore the obtained data includes the ID number, i.e., each data is identifiable. In order to secure fast and stable data transmission of the twelve pod system, the pods are chained with RS-485 cable (not to be seen from outside) which is suitable to multi-channel simultaneous data transmission. The data stored temporarily in the pods are then transferred to a computer through RS-232C cable and finally stored to the hard disk in the computer.

(3) Linkage to GPS

In the prototype system, position data of observation had to be input manually by looking up positioning device. Keeping position records for many probes were hard and tedious task. Position data itself can be taken from ship installed positioning device. However, a type of positioning device is different from ship to ship, and their interfaces and output data formats are different. So, we selected a certain model of GPS receivers as a part of this micro-BT system. Fortunately, GPS receiver has become popular and the cost is getting cheaper in recent years. In the improved system, the GPS receiver is connected to the controller (i.e., a computer) by RS-232C. The computer receives position data from GPS every 10 seconds and stores them in its hard disk with time data. A probe has own clock, and the clock is synchronized to that of computer by the time of beginning of data sampling (i.e., when it is taken out of the pod). The launching time of the probe is detected by obtained time-depth records (rapid depth change from zero to positive). The launching position of the probe can be obtained by comparing launching time of the probe with ship time/position dataset by GPS. Also retrieving position can be detected in the same process.

The launching/retrieving position and time data provide drifting velocities of longline. Uda (1934) displayed current system off the southern coast of Japan by using drifting data of longline and gillnet, and pointed out that the longline drift data had advantages to indicate large scale current because the gear is enormously long and is almost free from surface condition (the gear is mostly submerged). More recently, Mizuno (1995) detected annual signal of the variation of the Indonesian throughflow by using historical longline drift data. Accurate longline drift data can be collected much easier using this micro-BT system.

(4) Improvement of probe

Depth and temperature data of the prototype system had small noise (Figure 7 of Mizuno et al., 1996). By improving the electric circuit in the probe, the problem is cleared for the new system (Figure 2), although a little histerisis remains.

The power unit in the probe is also improved, and the data sampling period becomes longer than 40 hours from 15 hours for the prototype model. This sampling period is long enough for operation of commercial longliners. Moreover, the sampling interval makes changeable from 1 to 60 seconds. The interval can be set by software.

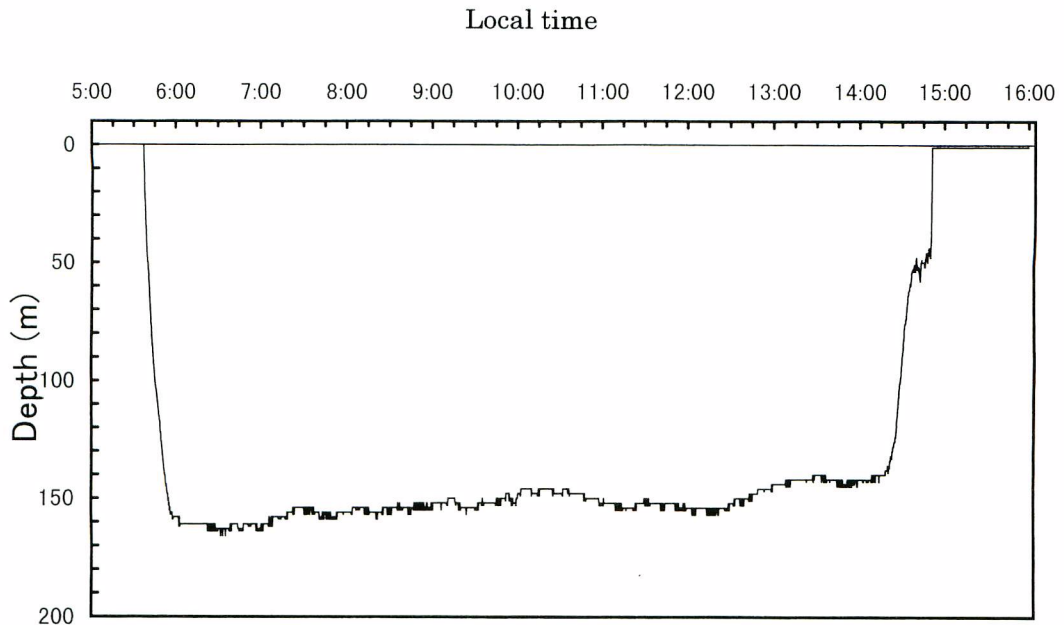

Fig. 2. An example of obtained data (time–depth profile, Jan. 27, 1997 : in the vicinity of $15^{\circ}46'S$, $118^{\circ}52'E$).

(5) Software

The software has been almost newly developed. The program is invoked on Windows 95/NT operating system. Most of the operation is executed by pointing device. Opening screen is shown in Figure 3. A menu bar appears beneath the title bar on the screen, and real-time position data received by GPS is also displayed.

Observed depth/temperature data by probes are temporarily stored in the pods shortly after the probes were returned to the pods. Clicking the "Pod Read" button prompts the computer to transfer the data to computer memory from the pods. This process can be monitored on a table displayed on a screen (Figure 4). In the table, connected probes are marked by solid circles and those probes which transmitted the data to the pods are also marked. The size of the table displayed on a screen restricts maximum number of simultaneously controllable probes to be thirty.

Clicking the "Data Save" button prompts the computer to save the data to the hard disk (Figure 5). Data files are stored into a hourly directory (ex. 970127-105611-tag15. sst ; recorded at Jan. 27, 1997 10:56:11 by No. 15 probe). A data file for each probe is generated under the name of its probe ID number.

Clicking the "Data Display" displays a graph of the data. Time–depth (Figure 6), time–temperature and temperature–depth graphs are selectable. In a graph, any data set can be selected up to eight data sets at a time.

Configuration of the entire system can be set by clicking the "Configuration" button. It con

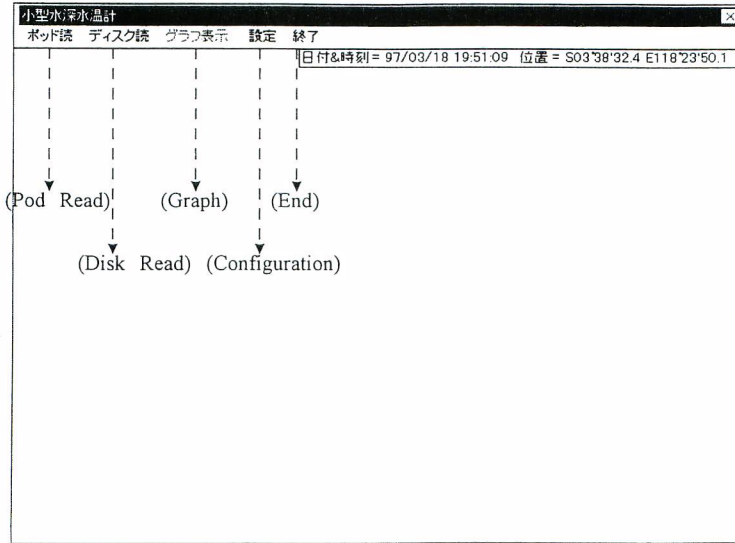

Fig. 3. Opening screen. A menu bar is displayed beneath the title bar at the top. It has five buttons which are "Pod Read" (reading observed data from pod), "Disk Read" (reading the data from the hard disk), "Graph" (displaying the data), "Configuration" (system configuration), and "End" (finishing the program). Position and time (UT) data received by GPS receiver are displayed at the right corner beneath the menu bar.

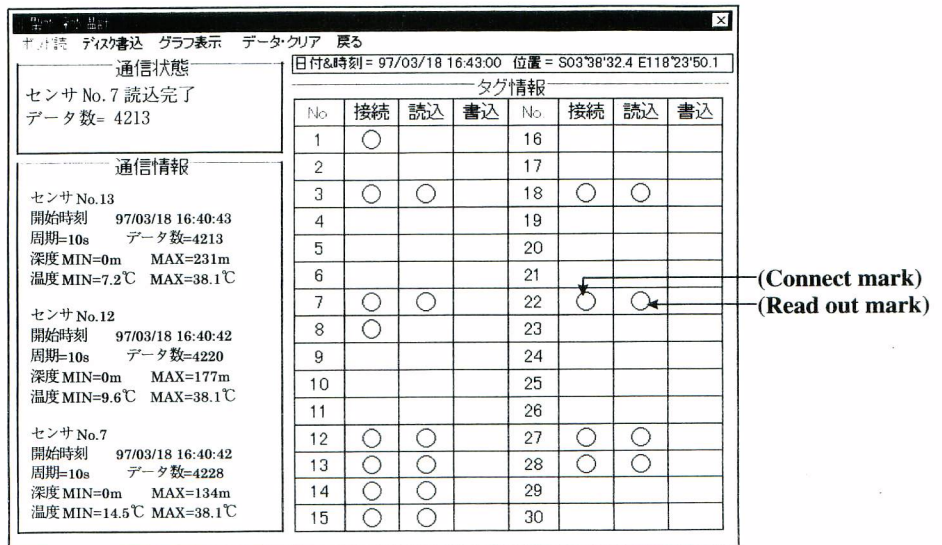

Fig. 4. A status table displayed by "Pod Read" button. In the right side table, probe ID numbers are displayed sequentially. ID numbers of probes connected to pods are marked by circles. Also those probes which transmitted their data to computer memory via pods are marked (Read out marks). Left side frames show realtime data transmission status (upper frame) and contents of transmitted data (lower frame).

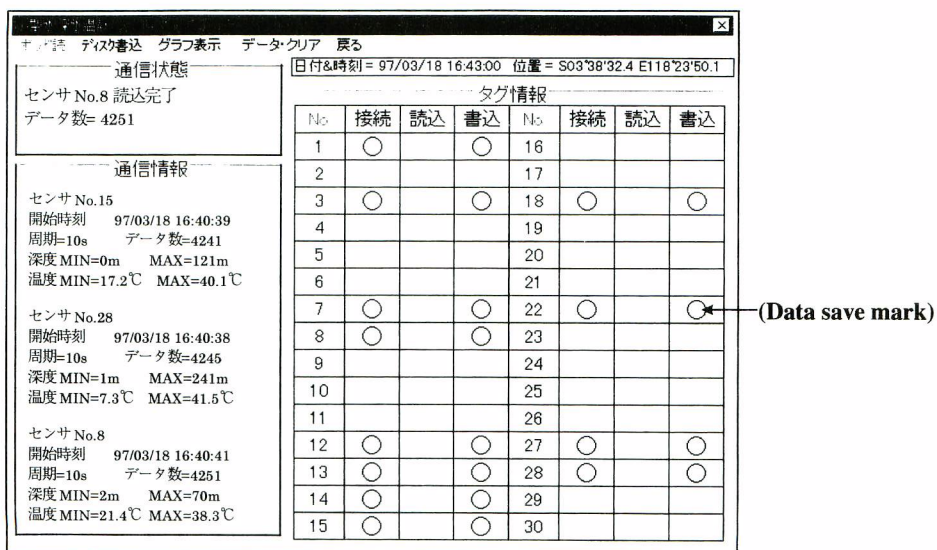

Fig. 5. A status table displayed by "Data Save" button. In the right side table, probe ID numbers of which data were saved on hard disk are marked by circles. Read out marks in Figure 4 disappear.

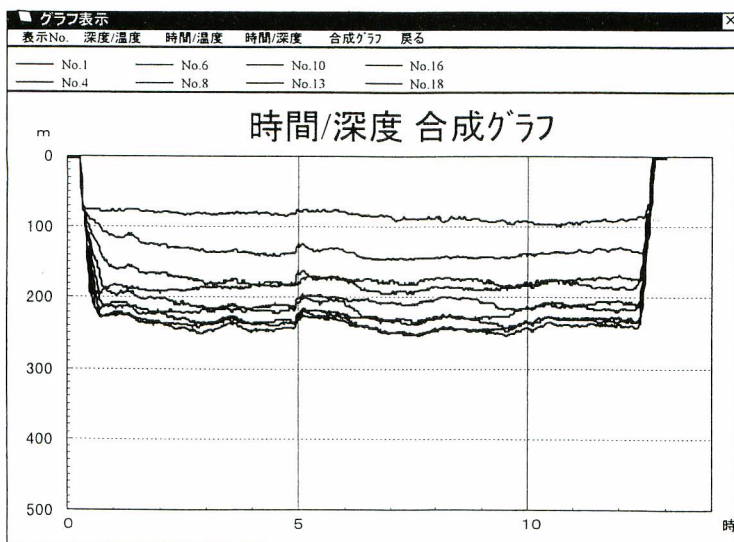

Fig. 6. Time-depth graph displayed by "Display Data" button. In this case, eight graphs are superimposed.

figures the total number of simultaneously controllable probes, a directory of data files, and the presence of the GPS receiver and a printer.

In order to decide the launching and retrieving position of the probe, ship position data during the operation period is necessary. So, the system should be continuously powered on during the period.

In-situ experiments and applicability

In order to check the depth/temperature precision and total performance of the system, in-situ experiments were made by taking advantage of several research cruises conducted by National Research Institute of Far Seas Fisheries. Several types of experiments were made to investigate its applicabilities to various fields of studies.

1) Depth/temperature precision

Fifty three probes were tied to a frame of CTD (Sea-bird SBE911plus) and lowered to 500m. The positions of the probes were adjusted to the same level of CTD sensors. When lowering, the CTD was stopped at every 50m interval for two minutes from surface to 500m. The data sampling interval was set to 1 second. After excluding the datasets which had suspicious data, 47 datasets were obtained. Temperature and depth data of probes are averaged at each stop, and were compared to the CTD data. The results are shown in Table 1. Based upon uncorrected data, temperature and depth errors are estimated to be 0.4°C and 4m. The temperature error is slightly larger than XBT (0.2°C; White and Bernstein 1979). On the other hand, the depth error is smaller than XBT (2%; White and Bernstein 1979). Data correction by linear fitting is able to reduce the errors in temperature and depth significantly to 0.05°C and 0.7m, respectively. In this case, the precisions are much better than XBT. So, this micro-BT system is bound to be usable for oceanographic studies. It is recommended to make cross-check test with CTD during each cruise. Otherwise, post-operation sensor correction are necessary.

Table 1. The precision of depth and temperature sensors obtained by comparison test with CTD (Dec. 29 1996). The uncorrected depth value of micro-BTs mean taking the depth in the air as 0m.

	Uncorrected	Linear fitting correction
Depth	4.2m	0.7m
Temperature	0.37°C	0.05°C

2) Hooking records

A set of 181 observations were totally made available by attaching the probes to branch line near the hook through longline operation during two scientific cruises (Shoyo-Maru 95-2 and 96-2

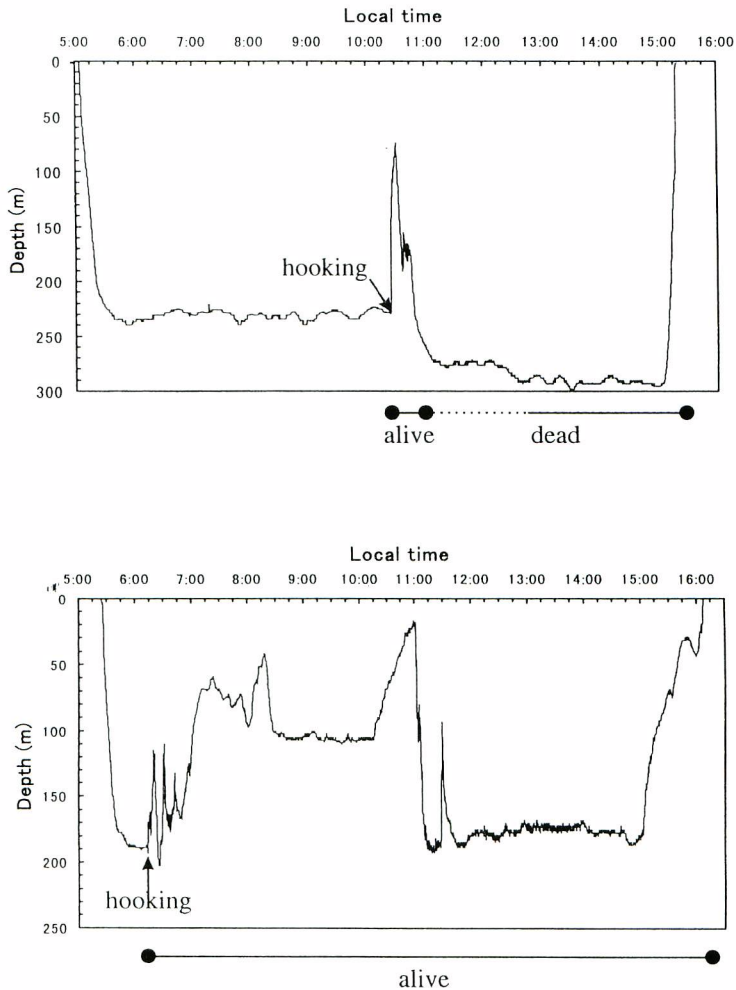

Fig. 7. Examples of time–depth data when a fish was hooked by a branch line with probe. Upper panel: A case of yellowfin tuna (*Tunas albacares*; Nov. 23 1995, Western tropical Indian Ocean). Lower panel: A case of bigeye tuna (*Tunas obesus*; Jan. 14 1997, Eastern Indian Ocean).

Indian Ocean cruises). Three examples with which fish hooked by the hook with micro-BT were obtained for tunas (two bigeye tuna and one yellowfin tuna). The number of obtained data was consistent with above estimated hook rate (1–2%) in the Pacific.

Examples of hooking data are displayed in Figure 7. The yellowfin tuna ceased vertical movement within 1 hour after hooking, then the hook depth became deeper than initial setting depth, which could have caused death of the fish. When retrieved on deck, it had been already dead. On the other hand, the bigeye tuna continued vertical movement, and it was retrieved on deck alive. Although the sample hooking data are few, it suggests that yellowfin tuna is more susceptible than bigeye tuna. It is consistent with the results of the survival rate for the longline

operation (Boggs 1992).

Even a fish is hooked in other branch line in a same basket, the hooking time is detectable (Figure 8).

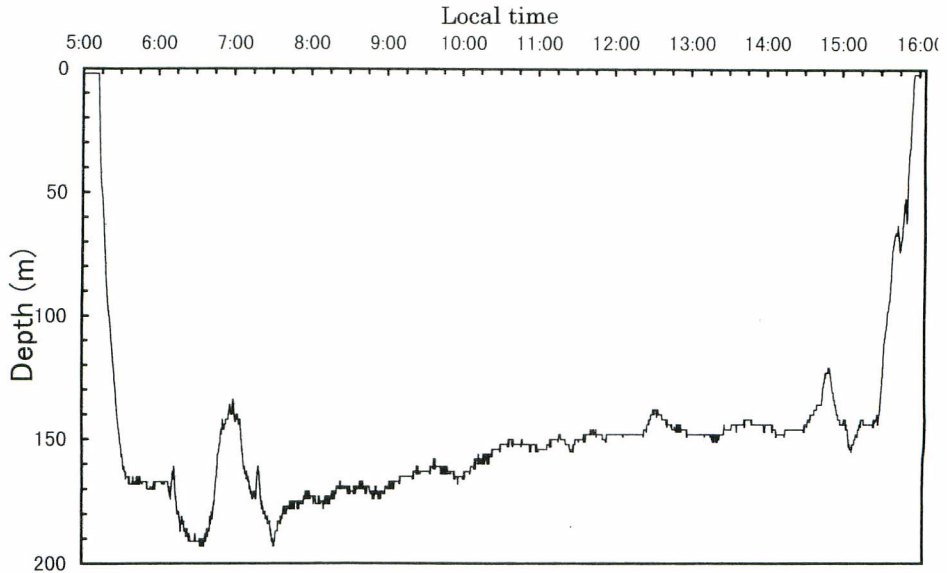

Fig. 8. An example of time–depth data when a fish was hooked by other branch line in the same basket.

A probe was attached to 7th branch line and two southern bluefin tuna (*Thunnus maccoi*) were hooked by 1st and 2nd branch line (Feb. 4 1997, Eastern tropical Indian Ocean). That of 1st branch line was alive on deck, but 2nd was dead.

3) Underwater longline shape

If a set of probes are attached to a main line in a basket (Figure 9), more detailed depths of the main line are obtained. Since the depths are known at attached points and the distances between the points are also known, the shape of the main line of the basket can be estimated under a certain reasonable assumption. Actually, Mizuno et al., (1997) developed a method for such estimation.

4) Micro–structure of upper ocean

Longline provides useful method to observe micro–structure of the upper ocean. Figure 10 shows vertical temperature sections obtained by the probes attached to central branch lines of a basket extending through 49 baskets (Figure 10). The spatial interval of each micro–BT is approximately 500m and total length of the observable section is 25km. Since vertical temperature profiles are obtained when setting and retrieving the gear, a pair of vertical sections can be obtained. The sections reveal micro–structure of upper ocean thermal field and its short–term change. In this case, depth of the thermocline did not change so much, however the thickness of

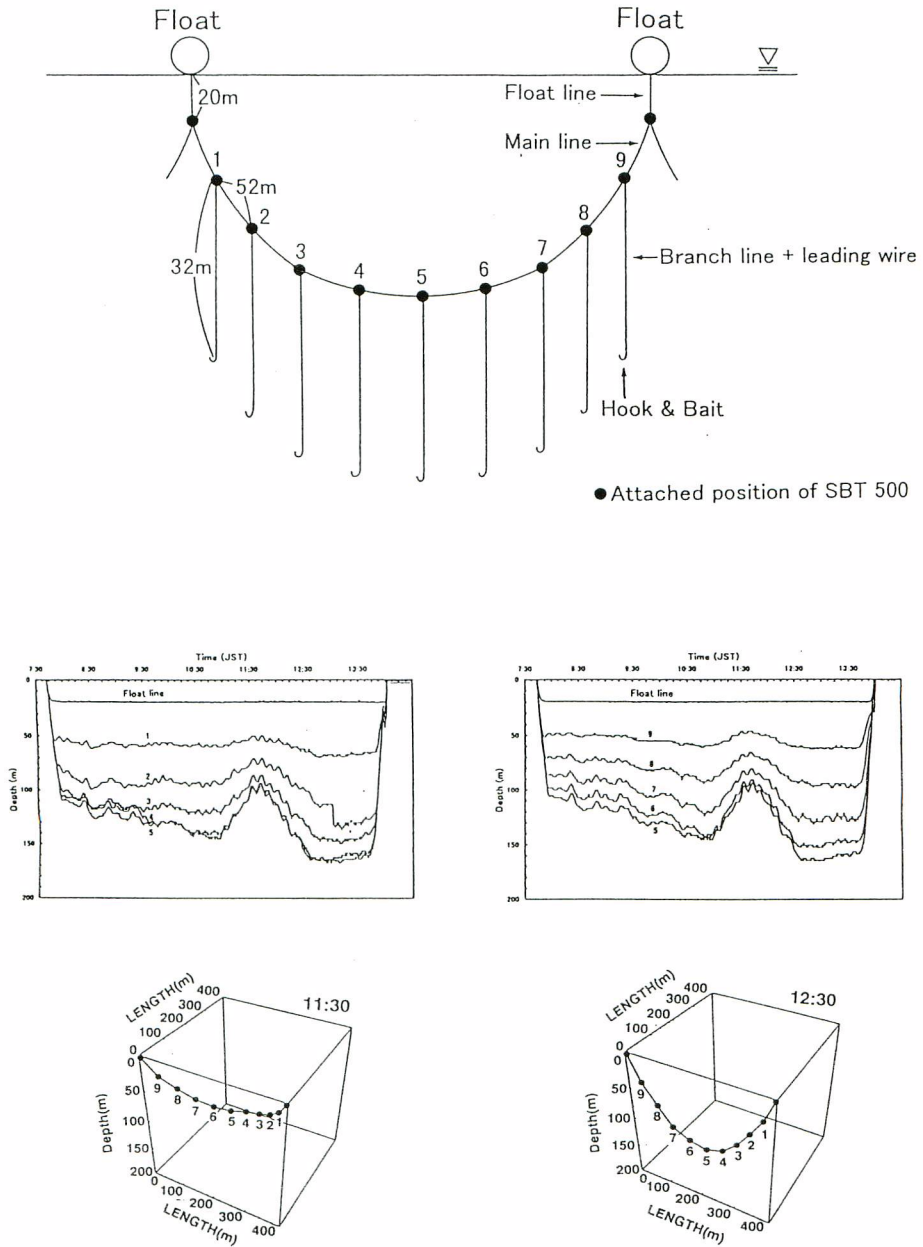

Fig. 9. Upper panel; Position of probes attached to main line in a basket (Jan. 21 1997). Middle panel; Time–depth records obtained by attached probe. Numerals on each record denotes the branch line number. Lower panel; Estimated underwater shape of mainline at certain times.

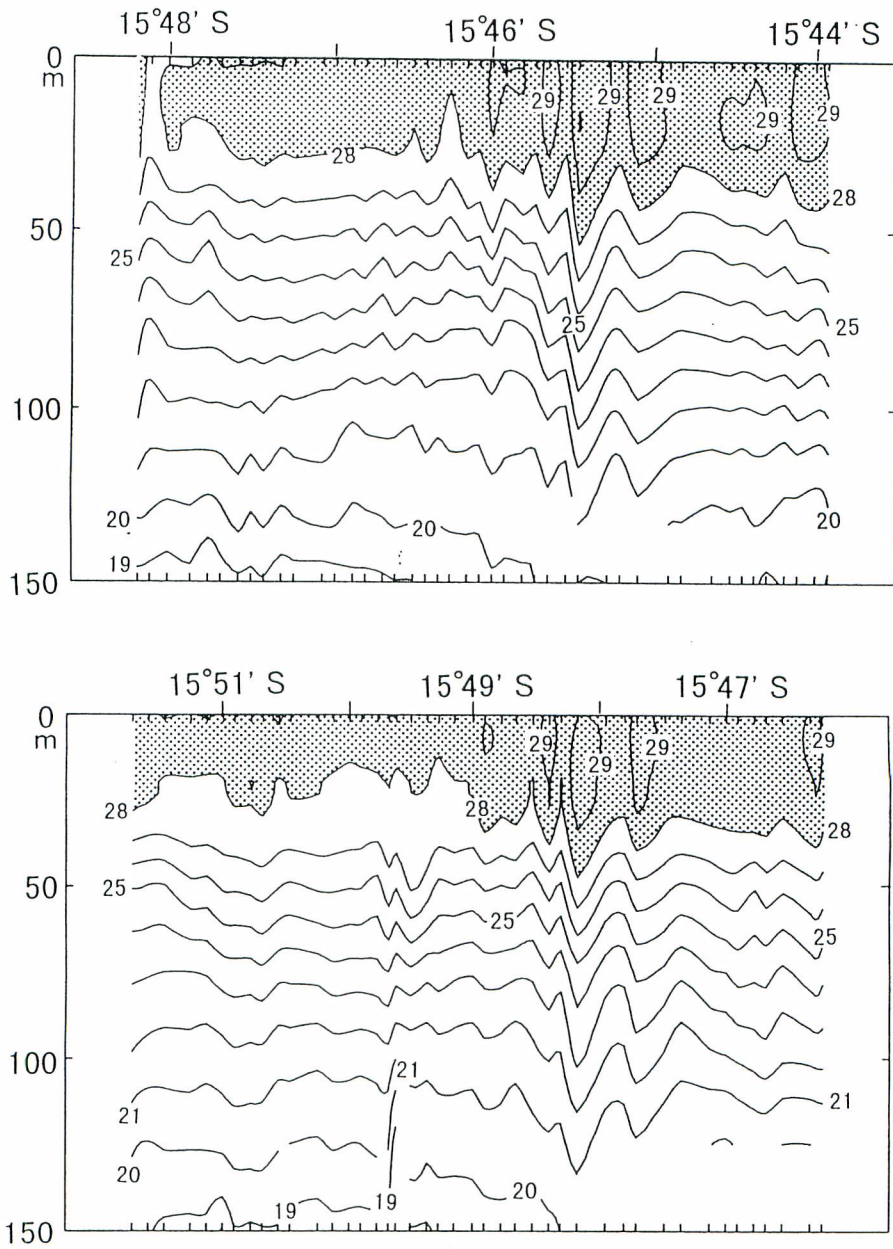

Fig. 10. A vertical temperature sections obtained when longline setting (upper panel), and retrieving (lower panel).

the surface mixed layer decreased significantly. It suggests that the heat is lost from the ocean, since the longline drifts along with the same surface water mass because of being free of the gear from the surface condition.

5) Drifting velocity

As mentioned previously, the system automatically detects position and time of launching and retrieving, which reflects upper ocean current system. An example of obtained launching/retrieving positions data is shown in Figure 11. The ship track obtained from shipboard GPS system for navigation is superimposed over these positions for checking the compatibility. Two kinds of data are quite consistent, and it demonstrates that the drifting velocity acquired by micro-BT would be usable for oceanographic study.

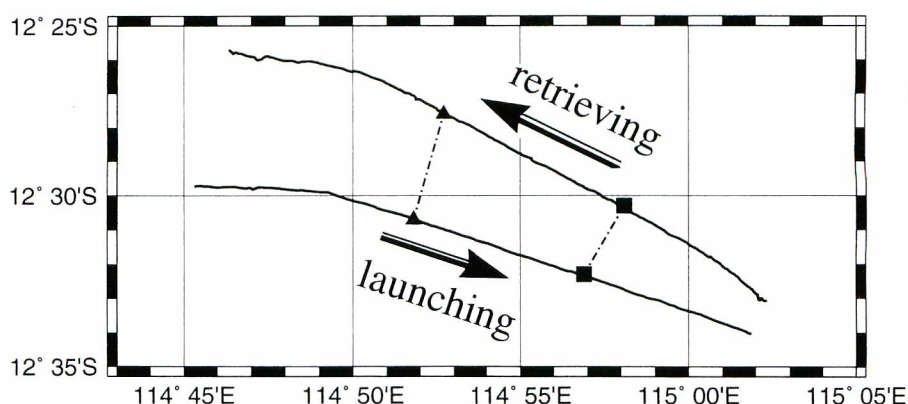

Fig. 11. Two sets of drifting position (▲, ■) obtained by the GPS attached to the micro-BT (Feb. 24 1997). Drifting is shown by broken line and the ship position by shipboard GPS during longline operation is shown by solid line.

6) Potential use for other purpose

The applicability of the system is investigated for other than longline fisheries. The time-depth record for squid handline using micro-BT is displayed in Figure 12. In the fisheries studies, handline investigations are often conducted in order to estimate the depth and size of the fish school. The problems of such investigation is that accurate catch depth and fishing effort (i.e., duration of fishing times and hook number) can not be obtained accurately. Because each handline operation is conducted by various style individually. The probe attached to a led at the end of handline supplies accurate fishing time and depth of bait. So, fishing effort is accurately obtained by micro-BT.

Another applicability is tested for trawling. A pair of probes are attached to the top/bottom of the net (Figure 13). The difference between the two indicates the height of the mouth of the net when towing. The information is useful for fishing operation, because the inadequate open

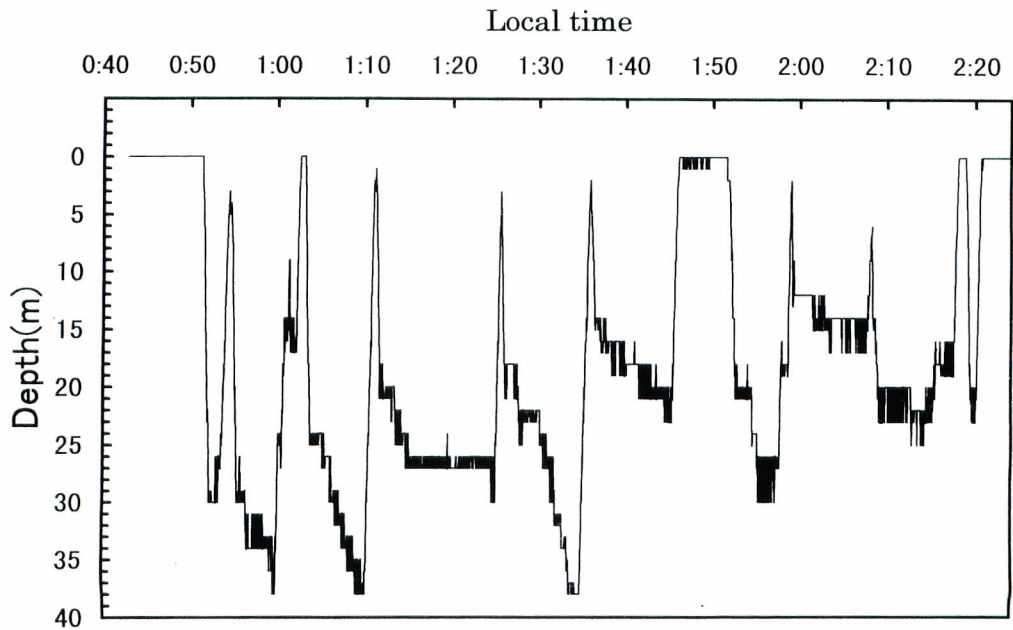

Fig. 12. The time-depth record for squid handline(Dec. 20, 1996).

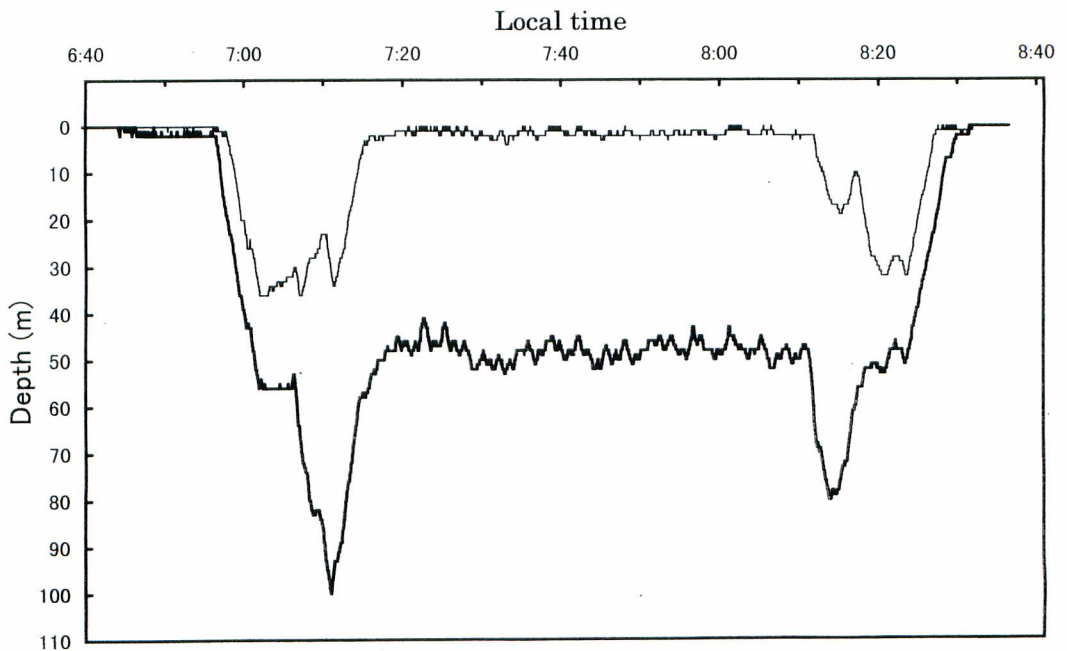

Fig. 13. The time-depth record obtained by a pair of probes attached to the top and bottom position of a mouth of trawnet (Oct. 15 1996, Kaiyo Maru).

ing of the net mouth can be checked immediately after the operation. Net recorder is available for this purpose. But it is bigger, more expensive and more unhandy than the micro-BT.

Discussion

The system is highly improved in several points as mentioned above compared to the prototype system. It is shown that multi-probe system supplies a number of applicabilities. One of the remained problems is that total probe number of simultaneously controllable probe is so far 30. The limitation is merely derived from software (i.e., a size of a table displayed on a screen). The memory size of pod and computer memory has enough capabilities to exceed this limit. It is desired to make the limit up to 48 which is the real limit of the data storage for the array of pods. By modifying the software (e.g. using scrollable table), the problem can be solved easily.

In terms of application to physical oceanography, one of the most important applications is to sample basin scale depth/temperature data taking advantage of wide operation area of longliners as pointed out Mizuno et al. (1996). So far as using longline as a platform, the maximum observation depth is expected to be approximately 200–250m. The depth is much shallower than XBT observation (typically 460m or 760m). The upper layer thickness in the tropical area can be indicated by 20°C isotherm which is consistent with the center of main thermocline. Referring to the long term monthly mean upper layer thickness maps by NOAA (1997), the thickness is less than 200m in most part in the Pacific and Indian Ocean. So the system is capable to supply D/T data for mapping of basin scale thermal field of upper ocean if many longliners are equipped by the system.

It is also shown that the system is applicable to small scale oceanographic study. Micro structure of the upper ocean can be displayed and its short term change can be detected. Also an applicability to heat flux study is suggested. More detailed and quantitative investigation is needed for the applicability to heat flux study in the future.

Applicability to fisheries operation seemed to have attained to a practical level. Hook depth monitoring is one of the most useful applications. Moreover, investigations on swimming depths and hooking time of tunas became possible by multi-probe system. In order to obtain 100 hooking data for tunas/billfishes, thousands of measurements are needed. If ten longliners use several probes in an operation, that number of data would be obtained in a year. Much more data are expected in terms of hooking time which is detectable by the probes which has a fishing data in other branch line in a same basket.

Summary

- (1) The prototype model was modified to multi-probe system having 12 pods array and 48 probes in consideration of fishing operation and biological studies.

- (2) By adding GPS receiver to the system, observed positions and drifting velocities of longline are obtained automatically.
- (3) The shipboard software has almost newly been developed. It makes the operation of the system much easier, and is capable of displaying obtained data graphically in various forms.
- (4) The precision of raw temperature and depth data was estimated to be 0.4°C and 4m, respectively. Data correction by linear fitting was able to suppress those errors to be 0.05°C and 0.7m, which are better than XBT.
- (5) In-situ experiment shows that the system has attained to a practically usable level for fishing operation, biological and oceanographic studies.
- (6) Examples of applicabilities of this system to fishing operation are shown by the estimation of underwater longline shape and the detection of hooking depth.
- (7) With 48 probes, one hooking record of tuna/billfish is expected in every two operations. Hooking record might be useful for the studies of tuna/billfish behavior.
- (8) The applicabilities to oceanography are shown by the micro structure of upper ocean, observed by the probes attached to central branch lines, and displaying the current system by using longline drift.

Acknowledgment

We acknowledge the captain Kan'ichi Yamanaka and his crew of Shoyo Maru for their cooperation with the in-situ experiments, and Dr. Hideki Nakano, Dr. Hiroaki Okamoto of our institute for helping us to conduct this experiment. This study was supported financially by the Agriculture, Forestry and Fisheries Research Council of Japanese Ministry of Agriculture, Forestry and Fisheries under the Kan-Min Koryu Kyodo Kenkyu project.

References

- MIZUNO, K., M. OKAZAKI, T. WATANABE and S. YANAGI 1996 : A Micro Bathythermograph System for Tuna Longline Boats in View of Large Scale Ocean Observing System. *Bull. Nat. Res. Inst. Far Seas Fish.*, **33**, 1-15.
- MIZUNO, K., M. OKAZAKI, H. NAKANO, H. OKAMURA 1997 : Estimation of underwater shape of tuna longline by using micro-BTs. *Bull. Nat. Res. Inst. Far Seas Fish.*, **34**, 1-15.
- NAKANO, H., W. H. BAYLIFF 1992 : A Review of the Japanese longline fishery for tunas and billfishes in the eastern pacific ocean, 1981-1987. *Inter-Amer. Trop. Tuna Comm. Bull.*, **20**(5), 187-355.
- RESOURCE DEPARTMENT OF FISHERIES AGENCY OF JAPAN 1982 : Annual Report of effort and catch statistics by area on Japanese tuna longline fishery 1980.
- WHITE, W. B., and R. BERNSTEIN 1979 : Design of an oceanographic network in the mid-latitude

North Pacific. *J.Phys.Oceanogr.*, **9**, 592-606.

C.H.BOGGS 1992 : Depth, capture time, and hooked longevity of longline-caught pelagic fish:

Timing bites of fish with chips. *Fishery bulletin U.S.*, **90**, 642-658.

NOAA 1997 : Climate diagnostics bulletin December 1996, 78pp

M.UDA 1934 : Oceanic currents estimate from the records of plying drift-nets and long-lines in fishing. *Bull.Japan.Soc.Sci.Fish.*, **3**(2) , 93-99

延縄用改良型水深水温計とその水産海洋学への応用

岡崎 誠・水野 恵介・渡邊 朝生・柳 新一郎

摘 要

延縄用小型水深水温計プロトタイプの上陸試験の結果に基づいてシステムを改良した。これによって多数のプロープを同時に用いた調査が可能となり，システムにGPS受信機を加えて観測位置と延縄漂移速度が得られるようにし，操作ソフトの取扱いは簡単になった。また，この新機能を生かした新システムの様々な用途を検討した。多数のプロープを延縄に使用することにより，縄の水中形状の把握が可能となり，まぐろ・かじき類の針がかりデータの取得についても実用レベルに達した。海洋学的研究に対しては，表層微細構造と表層流速の観測手法として有効であることを示した。